

# FROST

# Fighters

## PORTABLE HEATERS

INDIRECT FIRED SPACE HEATERS  
PROPANE AND NATURAL GAS



## MODEL IDH400QR LP/NG

Installation - Operation Maintenance  
Instructions and Parts List

READ INSTRUCTIONS PRIOR TO STARTING HEATERS

FROST FIGHTER INC.  
100-1500 NOTRE DAME AVE  
WINNIPEG, MANITOBA  
CANADA R3E 0P9  
TEL : (204) 775-8252  
FAX: (204) 783-6794



Rev. 1.3  
JUNE 2018

**WWW.FROST-FIGHTER.COM**  
**1-888-792-0374**

# FROSTFIGHTER WARRANTY

Frost Fighter Inc. warrants the Frostfighter heater to be free from defects in workmanship and materials for a period of twelve (12) months from date of initial service not to exceed fifteen (15) months from date of shipment.

If during the warranty period, the heat exchanger fails under normal use and service due to a defect in material or workmanship said heat exchanger will be repaired or replaced free of charge F.O.B. the Winnipeg Factory..

All mechanical and electrical components are covered by a one (1) year limited warranty. Normal maintenance items are excluded under the warranty. The warranty does **NOT** include any freight, labor or sales taxes incurred by the purchaser and is subject to the following conditions:

1. The heater shall be operated in accordance with the manufacturer's operating and maintenance manual.
2. The heater shall be subject to normal use in service and shall not have been misused, neglected, altered or otherwise damaged.
3. The unit shall be operated within the rated capacities and with the prescribed fuel.
4. The unit has not been allowed to exceed its proper temperature limits due to control malfunction or inadequate air circulation.
5. There is no evidence that the unit has been subject to tampering or deliberate destruction.
6. The heat exchanger shows no signs of an implosion or explosion.

No representative of Frost Fighter Inc., nor any of its distributors or dealers, is authorized to assume for Frost Fighter Inc. any other obligations or liability in connection with this product, nor alter the terms of the warranty in any way. This warranty is limited to the express provisions contained herein and does not extend to liability for labor costs incurred in replacing defective parts.

Parts can be obtained from Frost Fighter Inc, Winnipeg, Manitoba on the basis that credit will be issued if the defective parts returned qualify for replacement pursuant to the terms and conditions of this warranty. Authorization to return any alleged defective parts must be first obtained from the factory prior to transporting the part. A R.G.A.# must be provided from an Frost Fighter Inc representative. The transportation charges for the alleged defective part must be prepaid by the owner. Frost Fighter Inc. will not accept charges for parts purchased unless the conditions of this warranty have been satisfied and prior authorization to purchase the parts has been received from the factory.



100-1500 NOTRE DAME WINNIPEG, MANITOBA  
R3E 0P9, (204) 775-8252

# **INSTALLATION- OPERATION MAINTENANCE INSTRUCTIONS**

## **READ INSTRUCTIONS PRIOR TO OPERATING HEATER**

### **GENERAL HAZARD WARNING**

FAILURE TO COMPLY WITH PRECAUTIONS AND INSTRUCTIONS PROVIDED WITH THIS HEATER CAN RESULT IN DEATH, SERIOUS BODILY INJURY AND PROPERTY LOSS OR DAMAGE FROM HAZARDS OF FIRE, EXPLOSION, BURN, ASPHYXIATION, CARBON MONOXIDE POISONING, AND/OR ELECTRICAL SHOCK.

ONLY PERSONS WHO CAN UNDERSTAND AND FOLLOW THE INSTRUCTIONS SHOULD USE OR SERVICE THIS HEATING UNIT.

IF YOU REQUIRE ASSISTANCE OR HEATER INFORMATION SUCH AS AN INSTRUCTION MANUAL, LABELS, ETC., CONTACT THE MANUFACTURER.

### **WARNING**

FIRE, BURN INHALATION, AND EXPLOSION HAZARD. KEEP SOLID COMBUSTIBLES, SUCH AS BUILDING MATERIAL, PAPER AND/OR CARDBOARD A SAFE DISTANCE AWAY FROM THE HEATER AS RECOMMENDED BY THE INSTRUCTIONS. NEVER USE THE HEATER IN SPACES WHICH MAY CONTAIN VOLATILE OR AIRBORNE COMBUSTIBLES, OR PRODUCTS SUCH AS GASOLINE, SOLVENTS, PAINT THINNER, ACETONE, DUST PARTICLES AND/OR UNKNOWN CHEMICALS.

### **WARNING**

THIS PRODUCT IS NOT INTENDED FOR HOME OR RECREATIONAL VEHICLE USE.

### **FOR YOUR SAFETY**

DO NOT USE THIS HEATER IN A SPACE WHERE GASOLINE OR OTHER LIQUIDS HAVING FLAMMABLE VAPOURS ARE STORED OR USED.

### **GENERAL NOTES**

NATURAL/PROPANE GAS CODE: B149.1

ALL GAS INSPECTION AUTHORITIES IN CANADA REQUIRE THAT THE INSTALLATION AND MAINTENANCE OF HEATER AND ACCESSORIES SHALL BE ACCOMPLISHED BY A QUALIFIED GAS FITTER.

## **GENERAL NOTES:**

1. The heater is designed and approved for use as a construction heater under ANSI Z83.7 with the applicable requirements of UL 795 and under CGA 2.14 with applicable requirements of CAN/CSA 3.2. The intended use is for **5**, the temporary heating of building or structures under construction, alteration or repair.
2. Frost Fighter cannot anticipate every use, which may be made of our heaters.  
**CHECK WITH YOUR LOCAL FIRE AND SAFETY AUTHORITY IF YOU HAVE QUESTIONS ABOUT SAFE APPLICATIONS.**
3. Other standards govern the use of fuel gases and heat producing products in specific applications. Your local authority can advise you about this issue.
4. Please retain this instruction manual for future reference.
5. The primary application of this heater is for temporary heating of construction sites and/or applications of this type.

## **ELECTRICAL NOTES:**

1. All electrical connections and grounding shall be in compliance with the National Electrical Code and/or the Canadian Electrical Code (CSA Standard C22.1-98).
2. **WARNING:** Electrical grounding instructions... This appliance is equipped with a three prong(grounding) plug for your added protection against electrical shock hazard and should be plugged directly into a properly grounded three-prong receptacle.

## **ADDITIONAL INSTRUCTIONS FOR PROPANE GAS:**

1. Reference the Storage and Handling of Liquefied Petroleum Gas, ANSI/NFPA 58 and/or the National Standards of Canada CAN/CGA B149.2 installation codes for propane gas.
2. The heater must be located more than six (6) feet (1.83 meters) away from the propane source or propane tank.
3. When the heater is not in use insure to shut off the gas supply from the propane source or propane tank.
4. Disconnect the heater from the propane source or propane tank when storing the heater indoors.
5. The heater must not discharge toward any propane gas container within 20 feet (6 M).

## **INSTALLATION INSTRUCTIONS:**

6. The National Fuel Code, ANSI 223.1/NFPA 54 and/or National Standards of Canada CAN/CGA B149.1 installation codes must be followed as well as the recommendations of local authorities having jurisdiction.
7. Inspect the heater before each use and have it annually inspected by a qualified agency.
8. Inspect the hose assembly for wear, cuts, etc. and replace if necessary.
9. When firing the unit in an enclosed area, three square feet (0.278 square meters), must be provided to allow free entry of the air required for operation.
10. Do not operate the unit in partly ventilated areas without a flue pipe connected to the unit.
11. Do not operate the unit in close proximity to combustible surfaces and materials.
12. The cylinder supply system must be arranged to provide for vapor withdrawal from the operating cylinder.
13. Propane tank size should be a minimum 100 lbs. ( 90 liters)

## MODELS AND SPECIFICATIONS

<b>MODEL</b>	<b>IDH400QR LP/NG</b>
<b>HEATING CAPACITY</b>	390,000 BTU
<b>FUEL CAPACITY</b>	NATURAL GAS/ PROPANE
<b>POWER REQUIREMENTS</b>	115 VOLT 15 AMP
<b>BURNER MOTOR</b>	1/4 HP 3450 RPM
<b>MANIFOLD PRESSURE</b>	2.3" W.C. NAT GAS 2.0 " W.C. PROPANE
<b>MAXIMUM INLET PRESSURE</b>	14" W.C./ ½ LB
<b>MINIMUM INLET PRESSURE</b>	5.0" W.C.
<b>MINIMUM TEMP RATING</b>	-40°C/F
<b>FUEL CONSUMPTION PROPANE NAT GAS</b>	153 CU.FT. / 4.3 USGPH 362 CU.FT.
<b>APPROVAL AGENCY</b>	
<b>OVERALL DIMENSIONS</b>	70" X 35" X 52"
<b>HEATED AIR (W/O DUCT)</b>	2900 CFM
<b>WEIGHT</b>	467 LBS.

### MAXIMUM ALLOWABLE DUCT LENGTHS

**IDH400QR LPNG  
(390,000 BTU)**

75 feet 16" outlet ducting w/ NO 16" inlet ducting  
 50 feet 16" outlet ducting w/ 25 feet 16" inlet ducting  
 OR  
 75 feet 2 x 12" outlet ducting w/ NO 16" inlet ducting  
 50 feet 2 x 12" outlet ducting w/ 25 feet 16" inlet ducting

## INSTALLATION CLEARANCES

Top -6 inches (0.154 meters)  
Sides -24 inches (0.61 meters)  
Burner End 4 feet (1.21 meters)

Discharge End -10 feet (3.05 meters)  
Vent Connector -24 inches (0.61 meters)  
Floor- Combustible

### FLUE PIPE CONNECTION

1. Fasten rain cap on the end of the 36" (3 foot) flue pipe.
2. Fasten the open end of the flue pipe onto the flue of the unit.

Ensure that all venting and chimney layouts correspond to CSA B149 standard (Canada) or Ansi Z223.1/NFPA54 (US).

## INSTALLATION CLEARANCES

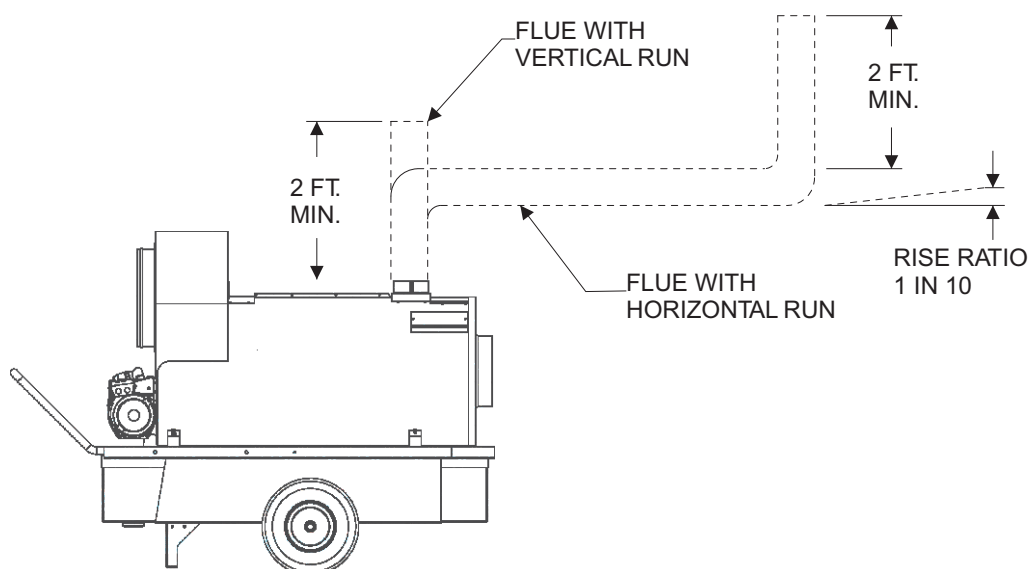

This drawing is for reference only. In Canada, the installation must be to the CSAB149.1 codes and in the U.S. To the National Fuel Gas Code ANSI Z223.1/NFPA54.

### CAUTION

1. The canopy must be closed to ensure operator(s) safety when operating the unit.
2. Do not shut off unit by disconnecting supply cord. The heat exchanger should be properly cooled Before power is disconnected from the heating unit.

**CAUTION:** Turning off the unit will stop the burner from operating but the supply fan will continue to operate in order to cool the heat exchanger.

For the equipment to function correctly, the proper regulator setup is required.

For all units 7"-14" Water Column is necessary at the supply to the unit.

**1**

## REG 1: 1ST Stage

Required if gas supply pressure is above 10 PSI & up to 250 PSI Max. To reduce pressure down to 5 - 10 PSI and supply 2nd stage regulator. P/N 50276A

**2**

## REG 2: 2nd Stage

Required if gas supply pressure is above 14" w.c. & up to 10 PSI Max. To reduce pressure down to the required 7"-14" w.c. for the heater. P/N 50276B

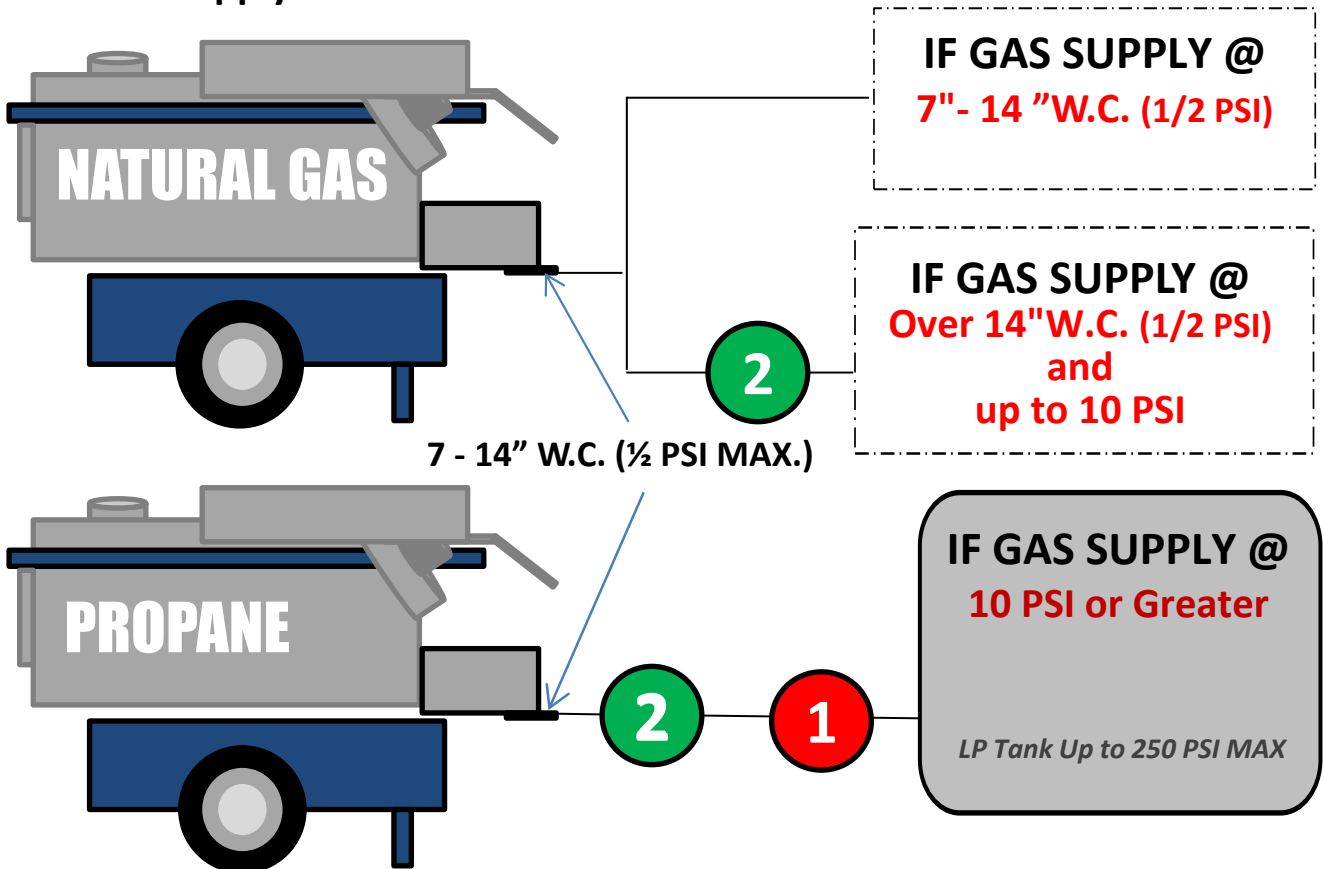

**NOTE: All piping/hoses must be as per national and/or local codes.**

## **OPERATING INSTRUCTIONS**

### **TO START HEATER**

1. Ensure unit is flat and level
2. Check that the operating switch on the unit is in the "OFF" position before plugging supply cord to a 115 VAC outlet.
3. **Ensure that gas supply is 14" ( ½ lb) pressure maximum that is being fed to the RV53 Maxitrol regulator.**
4. Check that the supply gas and conversion valves are set to the same gas type.
5. Once valve setting is verified, turn on main gas firing valves to open position
6. Plug power supply cord to a 115 VAC outlet.
7. Place operating switch to "MANUAL" position. This will start the unit.
8. For use with a thermostat, the operating switch should be placed to "THERM" position.

**\*\*IF HEATER FAILS TO START, REFER TO TROUBLE SHOOTING GUIDE\*\***

### **TO STOP HEATER**

1. Place the operation switch into the "OFF" position. Allow for automatic cool down of heat exchanger to occur before disconnecting power supply cord from outlet.
2. If operation switch is in "THERM" position and operating, place into "OFF" position and allow for automatic cool down of heat exchanger to occur before disconnecting power supply cord from outlet.

### **AIR DAMPER SETTING**

Damper adjustment will be required in colder weather and different elevations when there is reduced air density. The requirement will be that the damper be opened to allow more air into the burner. Adjustments may also be made to the damper of the burner when undesirable performance is observed -indicated by excessive pulsing or rumbling and/or smoke from the flue. Suggested air damper settings at sea level (IDH 400 QR = 1 to 1 1/2)

1. Locate the adjustable damper connection on the right hand side when facing the burner.
2. Loosen the nut on the adjustable connection, and manually move the damper connection until the desired position is achieved (i.e. no pulsations and/or smoke from flue).
3. Re-tighten the nut on the adjustable damper connection.
4. Do not adjust damper below 3/4 as unit will run too rich (fuel/air mixture) and carbon up spark rod.

### **NOTE:**

1. Adjust air damper and gas regulator pressure for elevation correction.
2. For elevations above 2,000 feet (610 meters), the unit will be de-rated four percent (4%) for every 1,000 feet (305 meters) of elevation above sea level.

### **ELECTRODE AND FLAME ROD SETTING**

1. Flame rod should be 1/8" above the retention plate (diagram on Page 15).
2. Electrode (porcelain end) should be 1/8" above the retention plate.



# STANDARD GAS CONVERSION PROCEDURE

CHECK TYPE OF GAS BEING USED FOR OPERATION. SUITABLE GASES ARE NATURAL GAS AND PROPANE GAS.

## Propane Gas

1. For propane gas use, the conversion valve must be placed in the propane gas position as per the label on the unit. This is the closed position of the red handled ball valve on the manifold. Handle should be 90° to the valve.
2. Once in the closed position, the valve must be locked in that position so that the unit will operate safely.

## Natural Gas

1. For natural gas use, the conversion valve must be placed in the natural gas position as per the label on the unit. This is the open or parallel position to the manifold. Red handled ball valve must be in line with the manifold.
2. Once placed in the open position, the valve must be locked in that position so that the unit will operate safely. Double check that you are using natural gas as propane used in this position could present a hazardous situation.

**PLEASE SEE BELOW DECAL. IF THERE ARE ANY QUESTIONS, PLEASE CALL THE FACTORY**

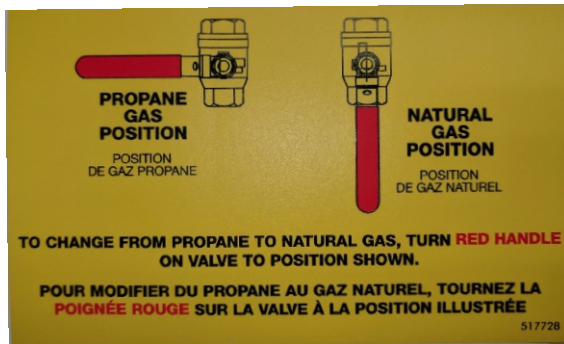

## IDH MAINTENANCE INSTRUCTIONS

**HEATERS SHOULD BE FULLY SERVICED ANNUALLY BY QUALIFIED PERSONNEL. LACK OF MAINTENANCE COULD RESULT IN HEATER NOT WORKING PROPERLY.**

### HIGH LIMIT SWITCH

The limit switch should be checked every heating season to ensure the burner will shutdown if temperature exceeds 300° F. To test the high limit, remove red braided high temperature wire from terminal one. Start unit and run till burner shuts down on high limit. Disconnect power from unit, reconnect red wire then start unit to cool down heat exchanger. If unit runs longer than 2 minutes or less than one minute before high limit fails, replace high limit.

### FAN SWITCH

The fan switch has been selected to allow for preheating of the heat exchanger to ensure that only heated air is allowed to enter the space. Upon satisfying the need for heat the fan switch will continue to run the supply fan until the heat exchanger has cooled sufficiently. This feature will help to prolong the life of your heat exchanger.

### GAS LEAKAGE TESTING

After removal for service or replacing components on the gas manifold a gas leakage test must be performed.

1. Close main gas firing valve on the gas manifold.
2. Connect your source gas to the gas manifold.
3. Once connections are tightened, open source gas, fire unit.
4. On each connection and fitting, apply soap solution and check for bubbles. This will indicate a gas leak if bubbles continue to form.
5. Fix any leaks that are found by applying pipe dope to the leaking fitting or connection and re-tighten. Check for leaks once repairs, if any, are made.
6. Open main gas firing valve and start the unit.
7. Once the unit is operating and burner is running, redo the soap test to insure gas fittings are tight.
8. Fix any leaks found.

# **IDH MAINTENANCE INSTRUCTIONS (CONT'D)**

## **AIR SWITCH**

The air switch should be tested regularly to ensure it will cut out if any blockage or disruption to burner airflow occurs. With the unit running, slide a 6" X 8" piece of cardboard upwards if front of screen on burner ( under control panel) slowly. When screen is 2/3 covered, solenoid valve(s) should close, shutting off gas supply. If necessary, adjust set screw clockwise if burner not cutting out soon enough.

## **FENWALL IGNITION MODULE**

Upon start up, LED light should flash once. If not, refer to trouble shooting guide. Once signal is detected (after 4 seconds of trial for ignition, TFI) shut off gas then turn back on. Unit should retry to light after 60 seconds. With unit running, turn off gas supply. Burner should stop firing and LED should flash 3 times. If you try to fire unit and no response but LED light is staying on, then replace Fenwall controller. With unit running, connect D.C. Micro amp multimeter probes to FC pins controller ( beside LED light). You should receive a reading between 3.5-5.5 microamp (fluctuating 10%). If reading is lower, check flame rod and wire as per trouble shooting instructions. Disconnect orange MVI wire from controller. Shut off gas and with AC voltage tester, check between 24v ground side of transformer and MVI terminal for voltage during TFI. Reading should be steady 24v.AC.

## **HEAT EXCHANGER**

### **Cleaning Procedures**

1. Remove the front cap (Part #48205/20205).
2. Remove the small cover panel (Part #48119/20119) located on the top of the unit between the flue and front cap (Part #48205).
3. Remove the fan thermostat cover on the outer jacket (Part #48112). Loosen thermostat and remove from jacket. Remove high limit thermostat cover (Part #48112).
4. Slide heat exchanger out of jacket and place front (discharge or closed) end face down on ground (Part #48115).
5. Access for combustion chamber and heat exchanger cleaning is provided through the burner head opening and by removing the heat exchanger cap ring(s) (Part#48115).
6. To reassemble, reverse procedure.

## **ELECTRODE DRAWER ASSEMBLY**

Should be removed when doing maintenance and flame and spark rod cleaned and checked for cracks or chips. Also inspect wires and connections. Do a continuity check between flame rod and end of wire to ensure good signal.

## **ELECTRICAL**

Ensure all conduit (BX) connectors are tight. Open plug in cord and check connections tight and no frayed wires exposed. Check inside connections in control box to ensure good connections.

## **FAN**

Check for dust or dirt build up on blades. Check for tightness of the bolts. Run heater to check for fan vibration. Replace fan if excessive vibration is noticeable.

## **MOTORS**

No lubrication is necessary since the bearings are the sealed type. Clean motor of existing dust or dirt.

## **IMPORTANT**

**15 AMP CIRCUIT-IDH400QR LPNG  
GROUNDED EXTENSION CORD UP TO 50 FEET-12/3 AWG  
OVER 50' TO MAX OF 100 FEET 10/3 AWG**

## SEQUENCE OF OPERATION

- 1-Flip toggle switch to either manual or thermostat position.
- 2-Red LED light on ignition controller will come on for 1 second
- 3-Burner fan motor will start, unit will pre-purge for 45 seconds
- 4-Spark ignitor energized for 4 seconds, gas solenoid valves will open during 4 second TFI ( trial for ignition)The unit has three trials for ignition before lockout.
- 5-Burner lights, ignitor stops and flame current is sensed by ignition controller.
- 6-When heat exchanger reaches certain temperature ( temperature setting on fan switch) the fan switch will make and start supply fan.
- 7-When unit is shut off, burner will shut down and supply fan will run until heat exchanger temperature is below fan switch set point.

## LP/NG TROUBLE SHOOTING GUIDE

***\*ALWAYS CHECK FOR SUFFICIENT POWER, GAUGE CORD, POLARITY AND GAS PRESSURE .POWER AND GAS SUPPLY MUST ALWAYS BE SHUT OFF/DISCONNECTED BEFORE REMOVING OR REPLACING ANY COMPONENTS ON THE HEATER\****

### 1-UNIT WILL NOT START

- A- Check for 115 volts AC across terminals 1 and 2. If no voltage check power source.
- B- Check for power across terminals 2 and 3. If no power, inspect toggle switch or thermostat, replace if faulty
- C- Check the thermal overloads on burner supply fan motor. Reset by pushing the red button on motor housing.
- D- Ensure proper connection to burner fan. If power is at connection, and neutral wire secure, replace burner motor.

### 2-RED LED LIGHT DOES NOT FLASH ON START UP

- A- Check for power across terminals 2 and 4. If no power remove high limit cover and check for power on high limit. If no power there inspect air switch and tubing. Adjust and/or replace as necessary. If high limit powered on one side only, replace high limit.
  - B- Check power at 2 amp fuse. Replace if faulty.
  - C- Check across 120v side of transformer for power. On 24v side, should be 24v. If not replace transformer.
  - D- Check across 5 amp fuse for power. Replace if faulty.
  - E- Check L1 connection to terminal 4, ensure good connection.
  - F- Ensure proper ground at gas primary.
  - G- Bad controller, check LED for steady on or flashing codes.
  - H- If LED light stays on during pre-purge cycle, replace ignition controller.
- 

### 3-BURNER WILL NOT IGNITE.

- A- Always make sure gas supply pressure is 14" (½ lb) or less as over that amount could cause damage to manifold regulator.
- B- Check gas pressure at 1/8" tap on elbow of manifold. Ensure pressure is correct  
If no pressure there, remove cover and check for 24v across solenoid valve wires. If voltage present, replace solenoid valve.
- C- If no voltage, at solenoid valve, check gas primary control to ensure wired and grounded properly. If wired properly, and still no voltage to solenoid replace gas primary.
- D- Remove the electrode assembly from burner housing. Shut off all manual gas valves then reset the unit. Install jumper wire between terminals 3 and 4. Lay electrode assembly across top of burner housing. Carefully check for spark across the ignition gap after 34 second pre-purge. If no spark, check for 120VAC at ignition transformer. If power there, replace transformer, no power, replace gas primary. If spark is arcing at another point other than tip of spark rod, ensure spark rod is in correct position. If it is then replace spark rod. After test remove jumper from terminals 3 and 4.

#### **4-BURNER IGNITES BUT THEN SHUTS DOWN**

A- Connect D.C. Micro amp multimeter probes to FC pins controller ( beside LED light). You should receive a reading between 3.5-5.5 microamp (fluctuating 10%) during the time it fires. If reading is lower, check flame rod and wire as per trouble shooting instructions. Disconnect orange MVI wire from controller. Shut off gas and with AC voltage tester, check between 24v ground side of transformer and MVI terminal for voltage during TFI. Reading should be steady 24v.AC. Check flame current coming back to gas primary. Flame current is the current that passes through the flame from the sensor to ground. The minimum flame current necessary to keep the system from lockout is 1 microamp. To measure flame current, connect an analog DC microammeter to the FC terminals (beside LED light). Meter should read 1 microamp or higher. If meter reads below "0" on scale, meter leads are reversed. Disconnect power and reconnect meter leads for proper polarity.

B- If flame current measures below 1 microamp, replace gas primary control

C- If no flame current measured, remove electrode assembly. Check continuity on flame rod wire. Inspect flame rod for chips or cracks. Clean if necessary. Check and clean nozzle. Ensure all connections are tight.

D- Supply gas pressure to unit must be the proper pressure. (Refer to manual) If wrong size line is used to correspond with length, you may have to adjust to ensure correct supply pressure at unit.

E-Check polarity, ensure no AC voltage on terminal 2. Voltage supply must be consistent 108-132 volts.

F- If you are running more than one unit off of a single gas source and one unit is shutting down, be sure size of hose is correct for the BTU's and the length of the hose. Check at test port on elbow to ensure proper and constant pressure to burner.

#### **5-MAIN SUPPLY MOTOR DOES NOT COME ON, UNIT SHUTS DOWN ON HIGH LIMIT**

A- Check temperature feeler, make sure it is in properly.

B- Jumper out fan switch to test motor. If you have voltage to motor and still does not start replace motor. Check line voltage to ensure proper voltage. Also check amp draw on motor, motor may be running too hot and not running due to thermal overload being tripped.

C- Replace fan switch if you have power on one side after unit heating up it does not make.

D- Replace high limit as it may be tripping too soon and not giving fan switch time to engage.

E- Make sure fan switch is at the correct temperature for conditions. See page 18 for settings.

#### **6-IF THE UNIT DOES NOT RUN SMOOTHLY AND QUIETLY**

A Check to ensure proper gas supply pressure and proper manifold pressure.

B Adjust the air setting on the adjustable damper connection.

**Table B.1**  
**Maximum capacity of propane in thousands of Btuh for Schedule 40**  
**pipe and plastic pipe, including fittings, for pressures of 11 in w.c.**  
**based on a pressure drop of 1 in w.c.**

(See Clauses 6.3.2, 6.3.5, B.2.3, B.2.4, and B.3.5.)

(a) Imperial

Length of pipe, ft	Pipe size (NPS)								
	1/2	3/4	1	1-1/4	1-1/2	2	2-1/2	3	4
10	386	807	1 520	3 121	4 676	9 005	14 353	25 374	51 754
20	265	555	1 045	2 145	3 214	6 189	9 865	17 439	35 571
30	213	445	839	1 722	2 581	4 970	7 922	14 004	28 564
40	182	381	718	1 474	2 209	4 254	6 780	11 986	24 447
50	162	338	636	1 307	1 958	3 770	6 009	10 623	21 667
60	146	306	577	1 184	1 774	3 416	5 445	9 625	19 632
70	135	282	530	1 089	1 632	3 143	5 009	8 855	18 061
80	125	262	493	1 013	1 518	2 924	4 660	8 238	16 803
90	118	246	463	951	1 424	2 743	4 372	7 729	15 765
100	111	232	437	898	1 345	2 591	4 130	7 301	14 892
125	98	206	388	796	1 192	2 297	3 660	6 471	13 198
150	89	186	351	721	1 080	2 081	3 317	5 863	11 959
175	82	172	323	663	994	1 914	3 051	5 394	11 002
200	76	160	301	617	925	1 781	2 839	5 018	10 235
250	68	141	266	547	820	1 578	2 516	4 447	9 071
300	61	128	241	496	743	1 430	2 279	4 030	8 219
350	56	118	222	456	683	1 316	2 097	3 707	7 561
400	52	110	207	424	636	1 224	1 951	3 449	7 035
450	49	103	194	398	596	1 148	1 830	3 236	6 600
500	46	97	183	376	563	1 085	1 729	3 057	6 235
600	42	88	166	341	510	983	1 567	2 770	5 649
700	39	81	153	313	470	904	1 441	2 548	5 197
800	36	75	142	292	437	841	1 341	2 370	4 835
900	34	71	133	274	410	789	1 258	2 224	4 536
1 000	32	67	126	258	387	746	1 188	2 101	4 285
1 200	29	61	114	234	351	676	1 077	1 903	3 882
1 400	27	56	105	215	323	622	991	1 751	3 572
1 600	25	52	98	200	300	578	922	1 629	3 323
1 800	23	49	92	188	282	542	865	1 529	3 118
2 000	22	46	86	178	266	512	817	1 444	2 945

*(Continued)*

# NATURAL/PROPANE BURNER COMPLETE

IDH400QR-----PART #50223A

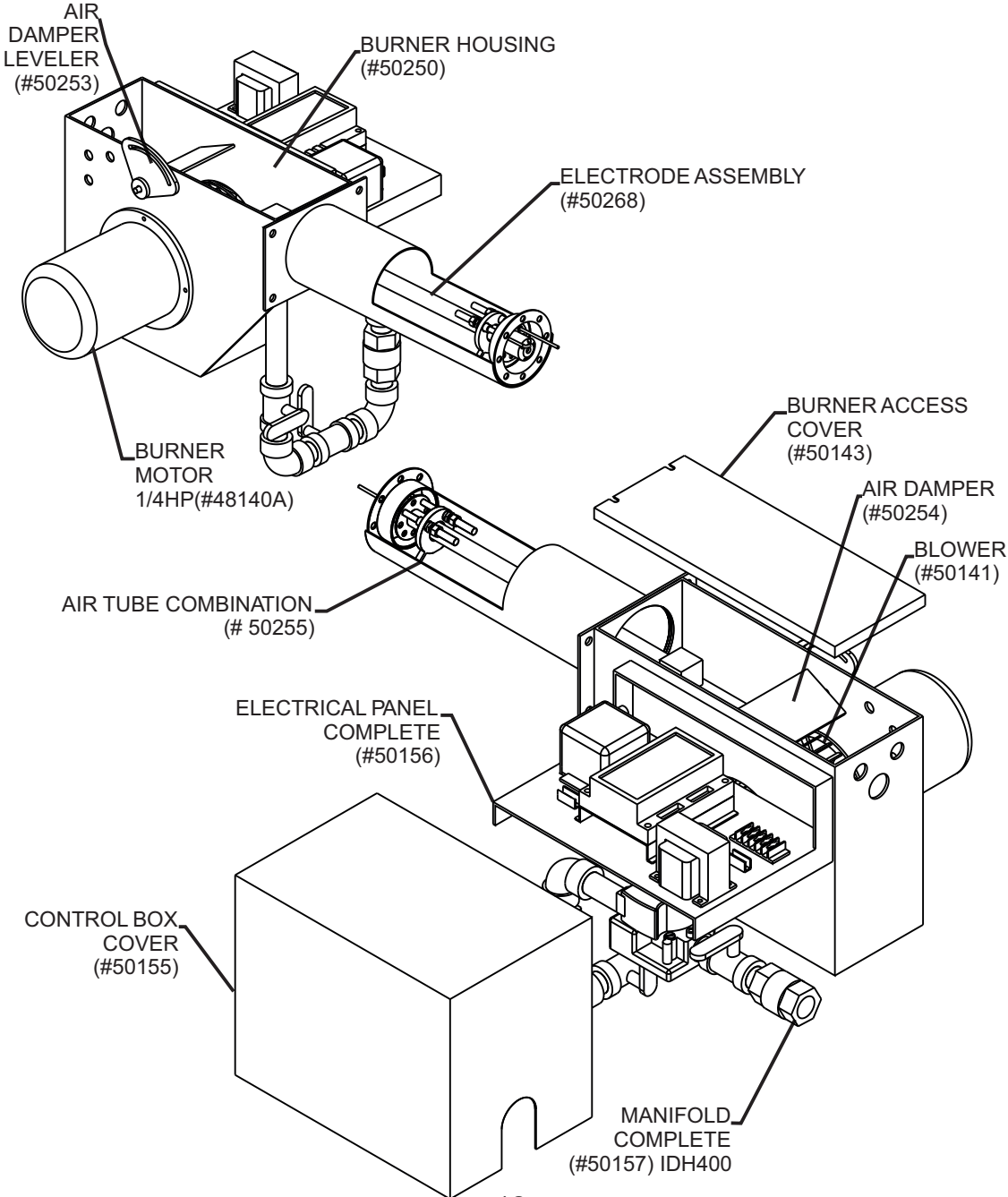

**ELECTRODE DRAWER ASSEMBLY (IDH400QR)  
(#50268)**

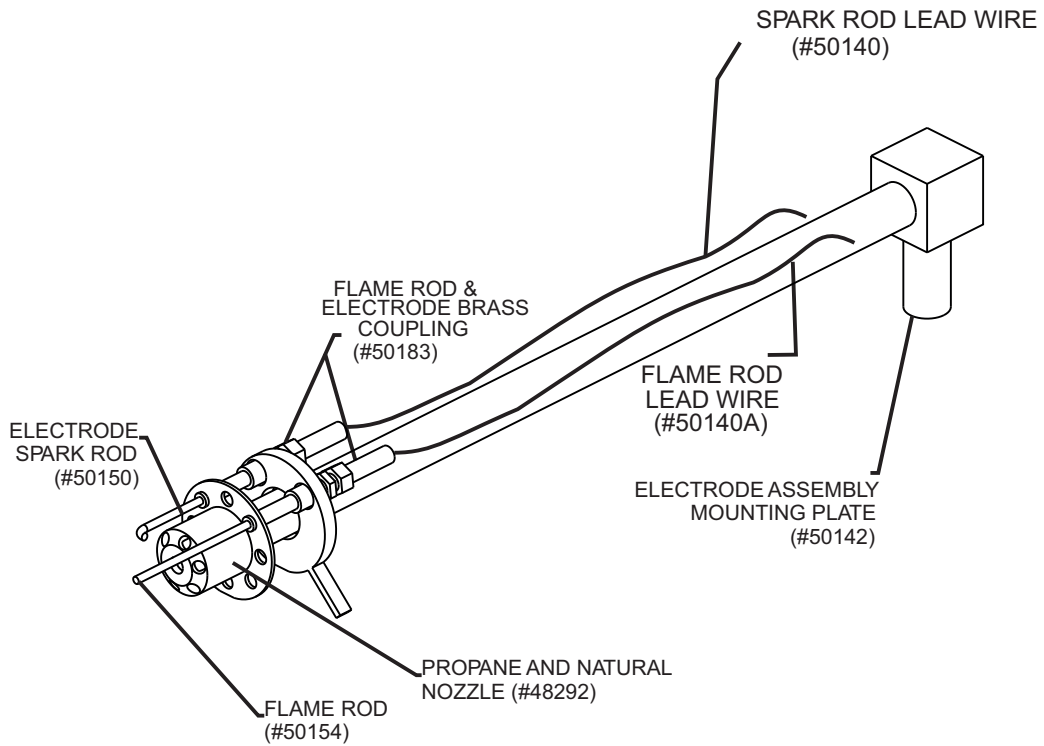

**BLAST TUBE ASSEMBLY (#50257)**

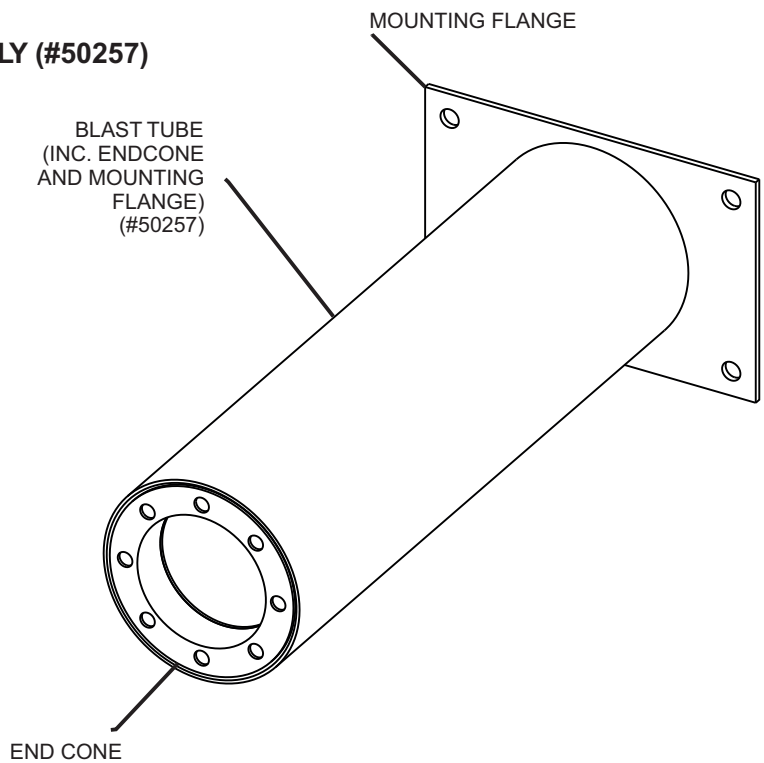

# ELECTRICAL PANEL (COMPLETE #50156)

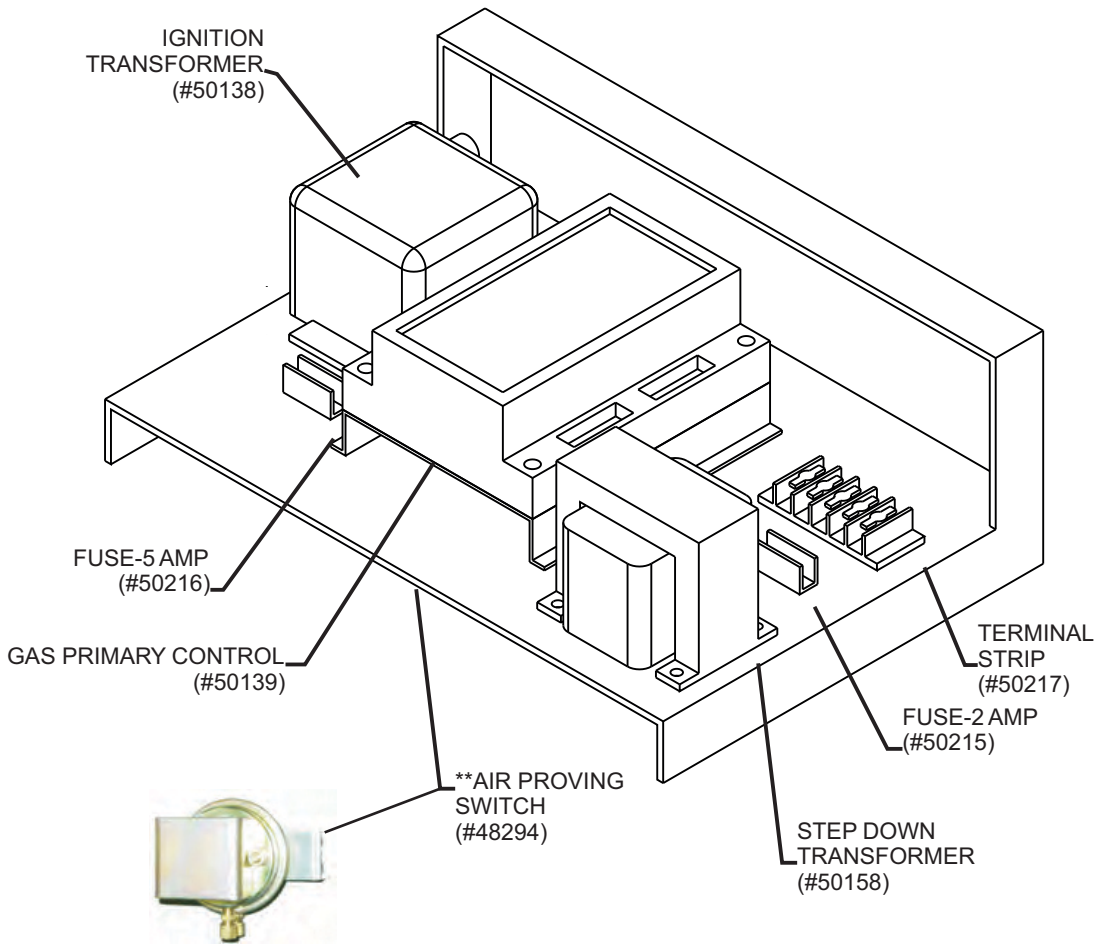

\*\*PLEASE NOTE: AIR PROVING SWITCH IS LOCATED UNDER THE ELECTRICAL PANEL



**MANIFOLD COMPLETE (IDH400QR)  
#50157**

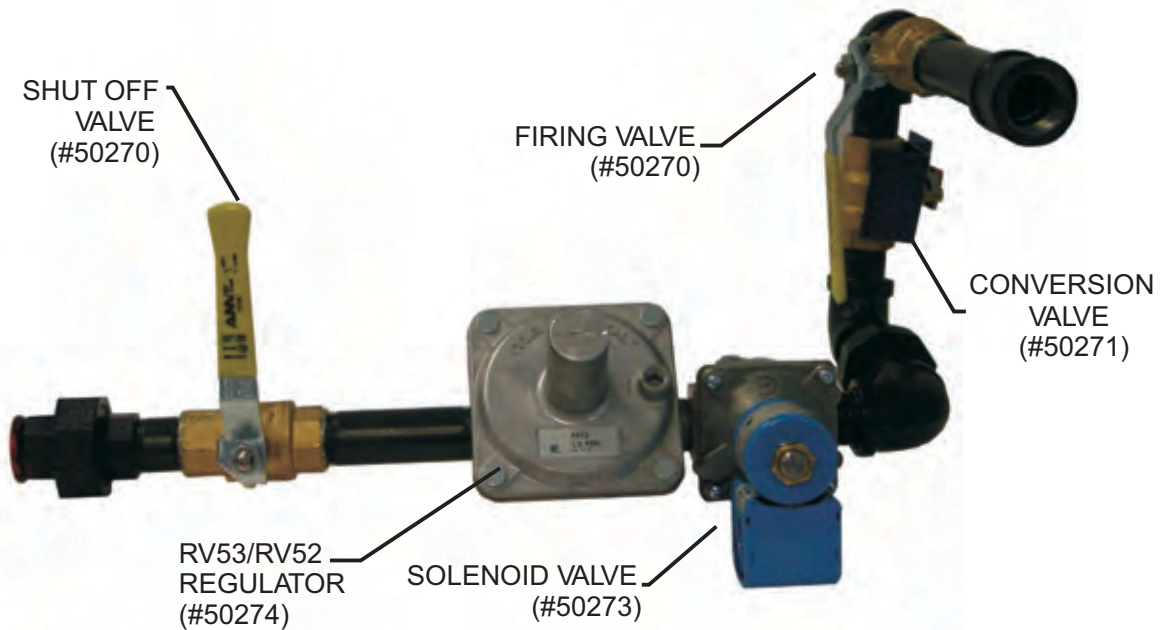

**NOTE: ALL UNITS WILL REQUIRE A "SECONDARY" POUNDS TO INCHES  
REGULATOR TO OPERATE ON PROPANE/NATURAL GAS**

## ELECTRODE AND FLAME ROD SETTINGS

ELECTRODE AND FLAME ROD SHOULD BE BOTH 1/8" ABOVE RETENTION PLATE.  
ENSURE TIP OF ELECTRODE IS IN THE MIDDLE OF GAS PORT

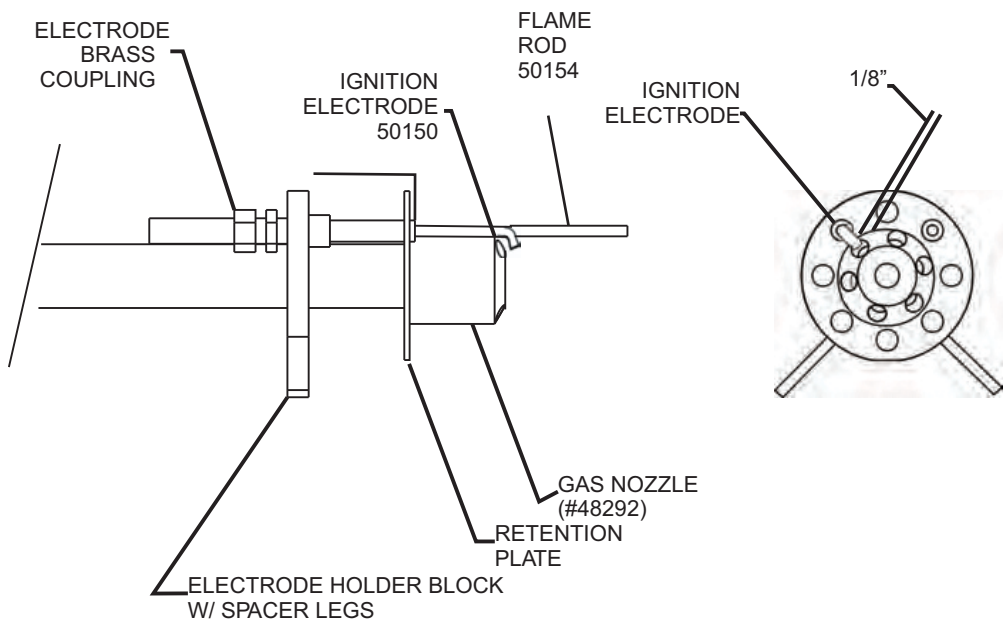

## LIMITS, FAN SWITCHES AND TEMPERATURE FEELERS

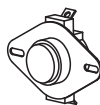

ADJUSTABLE FAN SWITCH 90-130°F ( 48111B)  
ALL MODELS



MANUAL HIGH LIMIT ( 48109)  
300°F

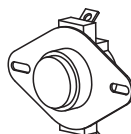

HIGH LIMIT L250-40F  
(48110C)  
250°F



FAN FEELER  
(48171)

### **Indoor and outdoor settings of fan switch**

Indoors & if surrounding air is warm i.e. -5C/23F-Fan switch should be set to 115°F or higher so as to shut down unit when heat exchanger is properly cooled, also keeps fan motor from excessive running on when discharging cooler air.

Outdoor-Fan switch should be set between 100'-90'. The colder the temperature the lower the setting.

# HIGH LIMIT/FAN SWITCH WIRING ON IDH400QR LP/NG HEATERS

—

ADJUSTABLE FAN  
SWITCH  
48111B

300°F MANUAL HIGH  
LIMIT SWITCH  
48109

250°F AUTOMATIC  
RESET HIGH LIMIT  
SWITCH 48110C

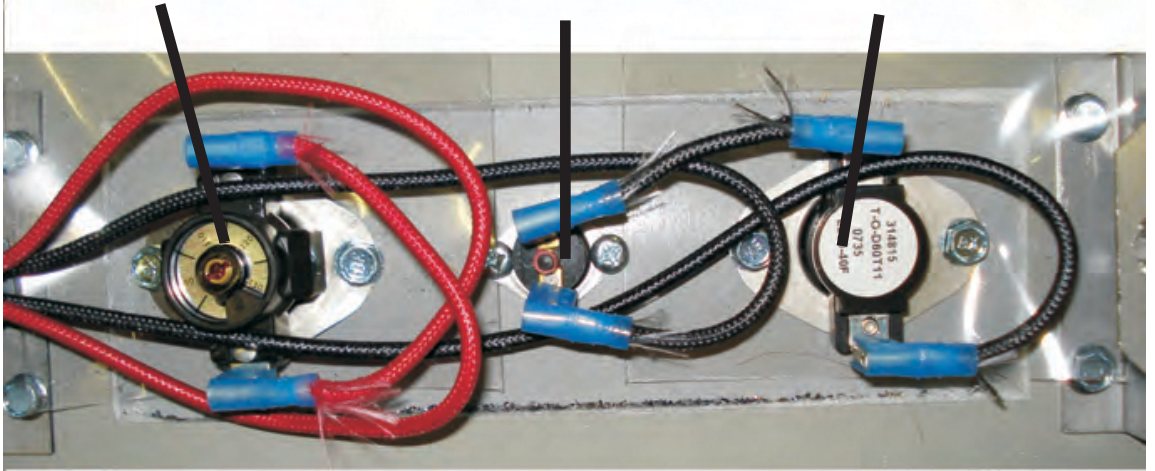

# IDH400QR LP/NG WIRING DIAGRAM

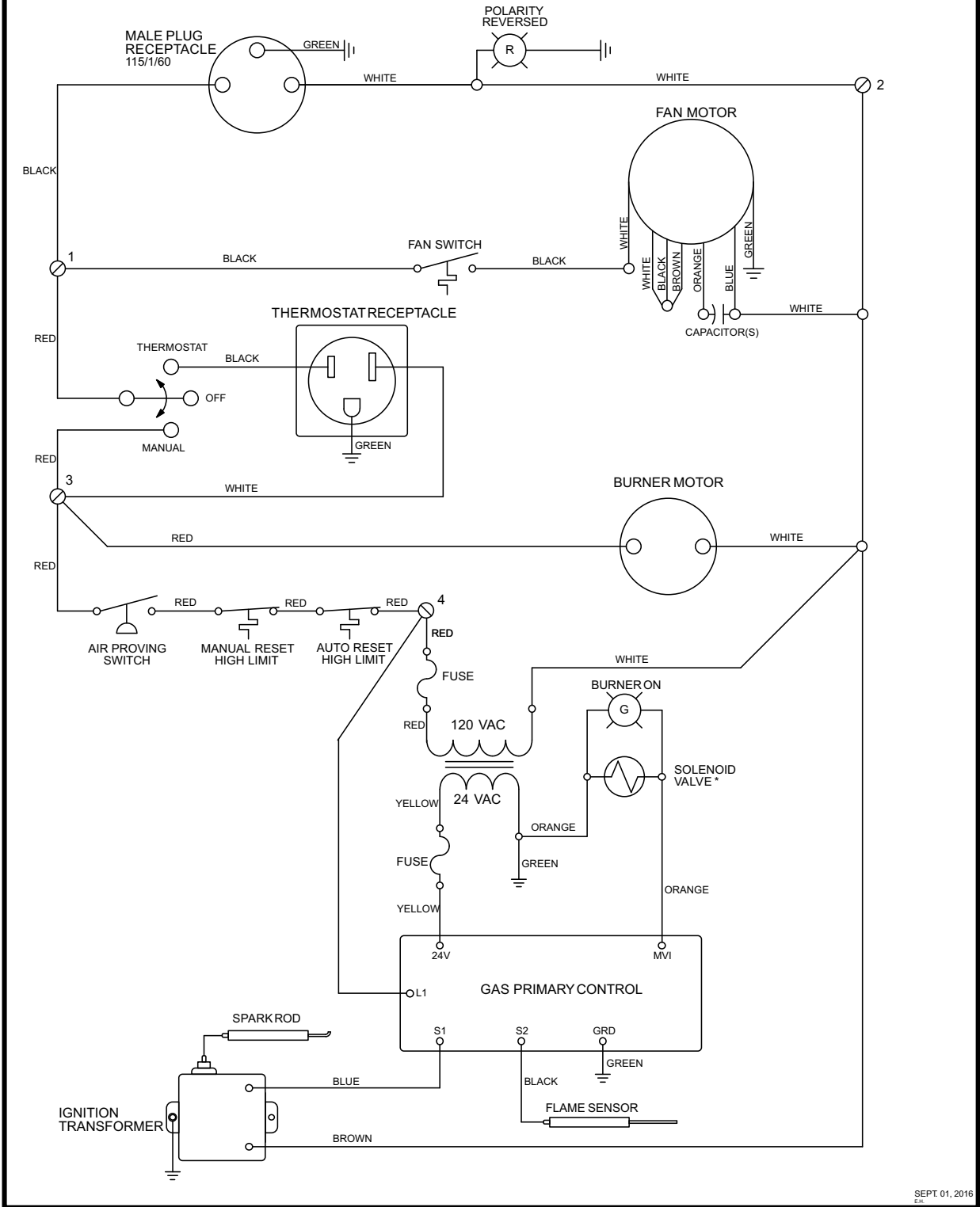

# IDH-QR LP/NG WIRING DIAGRAM

## (GP BURNER WITH POWER METER)

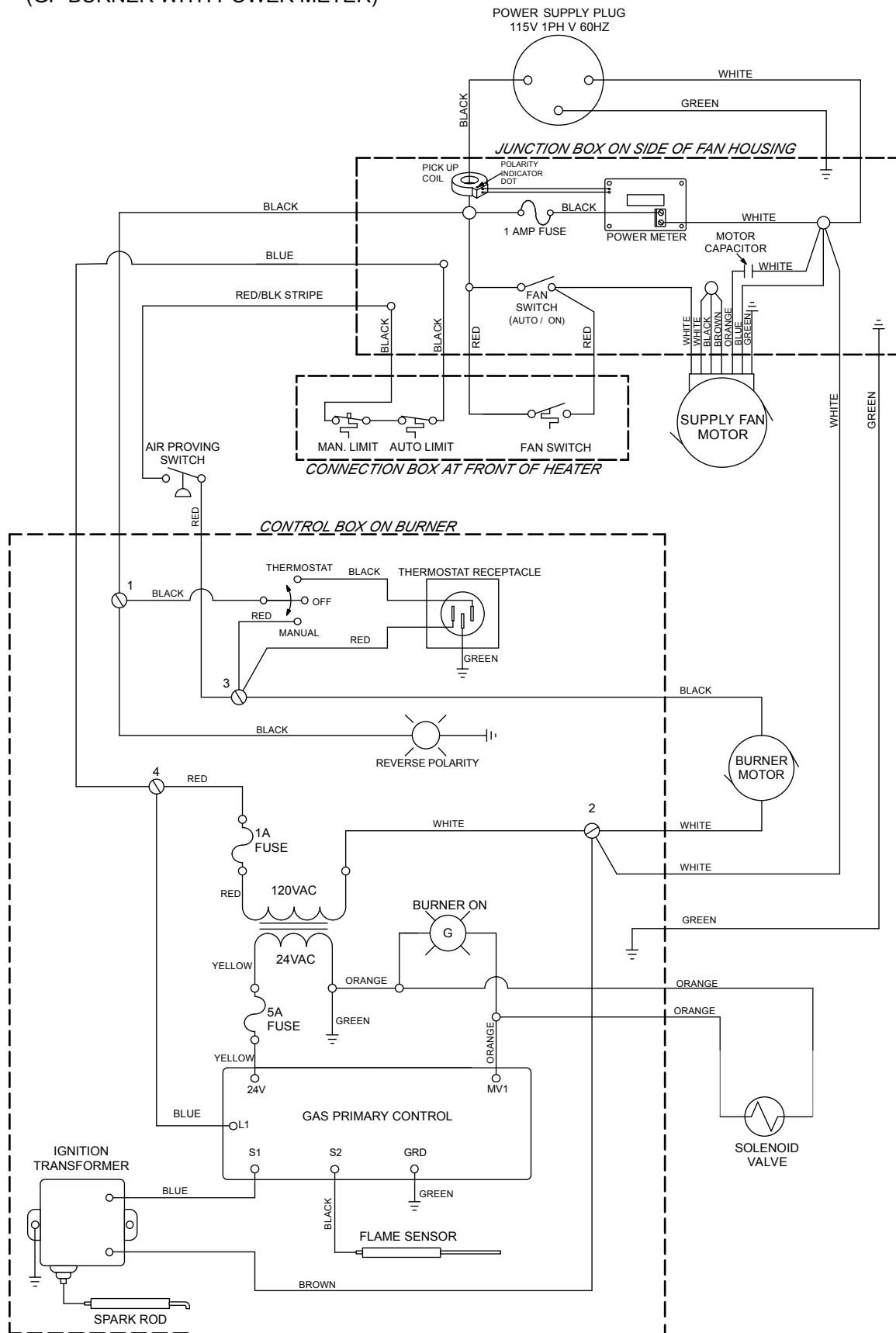

<b>PROPRIETARY AND CONFIDENTIAL</b> <small>THE INFORMATION CONTAINED IN THIS DRAWING IS THE SOLE PROPERTY OF FROST FIGHTER INC. ANY REPRODUCTION IN PART OR AS A WHOLE WITHOUT WRITTEN PERMISSION OF FROST FIGHTER INC. IS PROHIBITED</small>	MATERIAL	N/A	DRAWN	E.H.	<b>CIRCUIT DIAGRAM</b> <b>IDH-QR LP/NG W/POWER METER</b>	
	CUSTOMER		DESIGNED			
	TOLERANCES		DATE	07/20/18	SCALE	N/A
	X.X ±.1	FRACTIONS ±1/32	SCALE	N/A	SIZE	A
X.XX ±0.2	DRAFT ANGLE 3°	MODEL #	IDH400QR	REV	1	
X.XXX ±.005	RADIUS 1/8					

Frost Fighter IDH-QR Heaters after June 2018 may be equipped with optional power meter providing a real time display of critical information about the electrical power that is being supplied to the heater as well as heater's function and performance.

A bright 0.36"/9.2mm LED display is readable from up to 15 feet away which indicates the supply voltage, total amps, total watts or the line frequency by simply selecting which you wish to view. The display can also be set to continuously cycle through all four measurements.

Voltage measurement range is 85-264 VAC at 47-63HZ  
 Wattage is measured up to 9999 watts max.  
 Current is 0-32A with 0.01A resolution.

Display will accurately indicate real power and true rms current values of standard sine waves, triangle waves, square waves and other irregularly shaped waves with an accuracy of  $\pm 1\%$  full scale.

**DISPLAY SCREEN**  
 INDICATES SUPPLY VOLTAGE, TOTAL AMPS, TOTAL WATTS OR LINE FEQUENCY



**INDICATOR LIGHTS**  
 ILLUMINATES TO SHOW WHAT IS BEING MEASURED & DISPLAYED

**SELECTOR BUTTON**  
 ALLOWS USER TO SELECT WHAT VALUE TO READ OR CAN BE SET TO SCROLL

Momentarily pressing "SEL" button each time will cycle the display to the next measurement.

Holding the "SEL" button for 3 seconds will set the meter to continuously cycle through each measurement and display them for 3 seconds.

The meter can also be configured to always display the desired specific measurement such as amps or watts each time the heater is powered up. This is accomplished by setting the meter to the desired measurement reading and leaving it to display that reading without touching the "SEL" button for at least 60 seconds. Then each time the unit is powered up it will display that measurement.



**POWER METER**

**FAN SELECTOR SWITCH**

"AUTO" Norm. Temperature Controlled  
 "ON" Continuous Operation

**HEAT EXCHANGER FOR LP/NG UNITS**  
P/N 50200- IDH400QR LP/NG

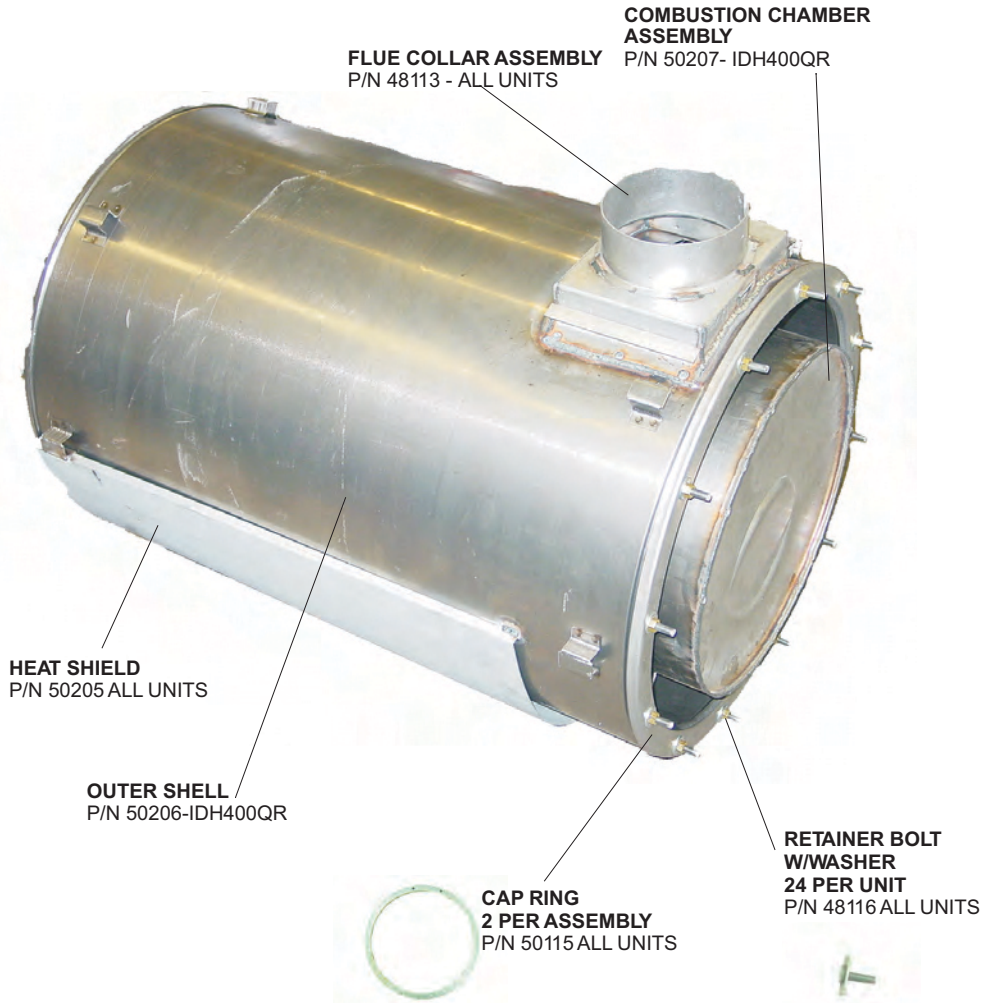



UNDER COVER  
CAPACITOR FOR FAN (50 uF)

48111B FAN SWITCH  
48110C AUTO RESET LIMIT 250°F  
48109 MANUAL RESET LIMIT 300°F

